



EN Operating instructions. pages 1 to 12
Original

7 Set-up and maintenance
7.1 Functional testing 9
7.2 Maintenance 9

8 Disassembly and disposal
8.1 Disassembly 9
8.2 Disposal. 9

9 Appendix
9.1 Wiring examples 10
9.2 Wiring configuration and accessories 11

10 EU Declaration of conformity

Contents

1 About this document
1.1 Function. 1
1.2 Target group: authorised qualified personnel 1
1.3 Explanation of the symbols used. 1
1.4 Appropriate use. 1
1.5 General safety instructions 1
1.6 Warning about misuse. 2
1.7 Exclusion of liability. 2

2 Product description
2.1 Ordering code 2
2.2 Special versions 2
2.3 Comprehensive quality insurance to 2006/42/EC 2
2.4 Purpose 2
2.5 Technical data 3
2.6 Safety classification. 4

3 Mounting
3.1 General mounting instructions. 4
3.2 Dimensions 4
3.3 Retrofit kit for Manual release/Emergency exit 5

4 Electrical connection
4.1 General information for electrical connection 5
4.2 Cable. 5

5 Operating principle and actuator coding
5.1 Magnet control. 5
5.2 Mode of operation of the safety outputs 5
5.3 Actuator teaching / actuator detection. 5

6 Diagnostic functions
6.1 Diagnostic-LEDs 6
6.2 Solenoid interlock with conventional diagnostic output 6
6.3 Solenoid interlock with serial diagnostic function SD 8

1. About this document

1.1 Function

This operating instructions manual provides all the information you need for the mounting, set-up and commissioning to ensure the safe operation and disassembly of the safety switchgear. The operating instructions must be available in a legible condition and a complete version in the vicinity of the device.

1.2 Target group: authorised qualified personnel

All operations described in this operating instructions manual must be carried out by trained specialist personnel, authorised by the plant operator only.

Please make sure that you have read and understood these operating instructions and that you know all applicable legislations regarding occupational safety and accident prevention prior to installation and putting the component into operation.

The machine builder must carefully select the harmonised standards to be complied with as well as other technical specifications for the selection, mounting and integration of the components.

1.3 Explanation of the symbols used



Information, hint, note:

This symbol is used for identifying useful additional information.



Caution: Failure to comply with this warning notice could lead to failures or malfunctions.

Warning: Failure to comply with this warning notice could lead to physical injury and/or damage to the machine.

1.4 Appropriate use

The products described in these operating instructions are developed to execute safety-related functions as part of an entire plant or machine. It is the responsibility of the manufacturer of a machine or plant to ensure the correct functionality of the entire machine or plant.

The safety switchgear must be exclusively used in accordance with the versions listed below or for the applications authorised by the manufacturer. Detailed information regarding the range of applications can be found in the chapter "Product description".

1.5 General safety instructions

The user must observe the safety instructions in this operating instructions manual, the country specific installation standards as well as all prevailing safety regulations and accident prevention rules.



Further technical information can be found in the Schmersal catalogues or in the online catalogue on the Internet: products.schmersal.com.

The information contained in this operating instructions manual is provided without liability and is subject to technical modifications.

There are no residual risks, provided that the safety instructions as well as the instructions regarding mounting, commissioning, operation and maintenance are observed.

1.6 Warning about misuse



In case of improper use or manipulation of the safety switchgear, personal hazards or damages to machinery or plant components cannot be excluded. The relevant requirements of the standard ISO 14119 must be observed.

1.7 Exclusion of liability

We shall accept no liability for damages and malfunctions resulting from defective mounting or failure to comply with this operating instructions manual. The manufacturer shall accept no liability for damages resulting from the use of unauthorised spare parts or accessories.

For safety reasons, invasive work on the device as well as arbitrary repairs, conversions and modifications to the device are strictly forbidden, the manufacturer shall accept no liability for damages resulting from such invasive work, arbitrary repairs, conversions and/or modifications to the device.

2. Product description

2.1 Ordering code

This operating instructions manual applies to the following types:

AZM201 ①-②-③-T-④-⑤

No.	Option	Description
①	Z	Solenoid interlock monitored
	B	Actuator monitored
②		Standard coding
	I1	Individual coding
	I2	Individual coding, re-teaching enabled
③	SK	Screw terminals
	CC	Cage clamps
	ST2	Connector plug M12, 8-pole
④	1P2PW	1 p-type diagnostic output and 2 safety outputs, p-type (combined diagnostic signal: guard system closed and interlock engaged)
	SD2P	Serial diagnostic output and 2 p-type safety outputs
⑤		Power to unlock
	A	Power to lock

Actuator	suitable for
AZ/AZM201-B1-...	Sliding safety guards
AZ/AZM201-B30-...	Hinged safety guards
AZ/AZM201-B40-...	Hinged-doors with overlapping folds



Only if the information described in this operating instructions manual are realised correctly, the safety function and therefore the compliance with the Machinery Directive is maintained.

2.2 Special versions

For special versions, which are not listed in the order code below 2.1, these specifications apply accordingly, provided that they correspond to the standard version.

2.3 Comprehensive quality insurance to 2006/42/EC

Schmersal is a certified company to appendix X of the Machinery Directive. As a result, Schmersal is entitled to autonomously conduct the conformity assessment procedure for the products listed in Appendix IV of the MD without involving a notified body. The prototype test certificates are available upon request or can be downloaded from the Internet at www.schmersal.com.

2.4 Purpose

The non-contact, electronic safety switchgear is designed for application in safety circuits and is used for monitoring the position and locking of movable safety guards.



The safety switchgears are classified according to ISO 14119 as type 4 interlocking devices. Designs with individual coding are classified as highly coded.

The different variants can be used as safety switch with interlocking function either as solenoid interlock.



If the risk analysis indicates the use of a monitored interlock then a variant with the monitored interlock is to be used, marked with the symbol in the ordering code. The actuator monitoring variant (B) is a safety switch with an interlock function for process protection.

The safety function consists of safely switching off the safety outputs when the safety guard is opened and maintaining the safe switched off condition of the safety outputs for as long as the safety guard is open.



Interlocks with power to lock principle may only be used in special cases after a thorough evaluation of the accident risk, since the safety guard can be opened immediately on failure of the power supply or upon activation of the main switch.

Series-wiring

Series-wiring can be set up. The reaction and risk times increase by up to 1.5 ms per additional device when connected in series. The quantity of devices is only limited by the cable drops and the external cable fuse protection, according to the technical data.

Series-wiring of up to 31 AZM201...-SD components with serial diagnostics is possible. In devices with the serial diagnostics function (ordering suffix -SD), the serial diagnostics connections are wired in series and connected to a SD Gateway for evaluation purposes.

Wiring examples for series-wiring, refer to appendix.



The user must evaluate and design the safety chain in accordance with the relevant standards and the required safety level. If multiple safety switchgears are involved in the same safety function, the PFH values of the individual components must be added.



The entire concept of the control system, in which the safety component is integrated, must be validated to the relevant standards.

2.5 Technical data

Standards:	EN 60947-5-3, ISO 14119, EN ISO 13849-1, EN 61508
Enclosure:	glass-fibre reinforced thermoplastic, self-extinguishing
Working principle:	RFID
Frequency band:	125 kHz
Transmitter output:	max. -6 dBm
Coding level according to ISO 14119:	
- I1-version:	high
- I2-version:	high
- Standard coding version:	low
Reaction time, switching off outputs Y1, Y2 via:	
- Actuator:	≤ 100 ms
- Inputs X1, X2:	≤ 1.5 ms
Duration of risk:	< 200 ms
Time to readiness:	< 4 s
Series-wiring:	Unlimited number of components, please observe external cable protection, max. 31 components in case of serial diagnostics
Cable length:	max. 200 m (cable length and cable section alter the voltage drop depending on the output current)
Mechanical data	
Holding force F_{max} :	2,600 N (1,300 N when used with the AZ/AZM201-B30 actuator, for indoor use)
Holding force F_{zh} :	2,000 N (1,000 N when used with the AZ/AZM201-B30 actuator, for indoor use)
Latching force:	30 N
Termination:	Screw terminals or cage clamps, Connector plug M12
Cable entry:	M20
Cable type:	rigid single-wire, rigid multi-wire or flexible
Cable section:	min. 0.25 mm ² , max. 1.5 mm ² (including conductor ferrules)
Tightening torque for the cover screws:	0.7 ... 1 Nm (Torx T10)
Actuating speed:	≤ 0.2 m/s
Mechanical life:	≥ 1,000,000 operations
Ambient conditions	
Ambient temperature:	-25 °C ... +60 °C
Storage and transport temperature:	-25 °C ... +85 °C
Relative humidity:	max. 93 %, non condensing, non icing
Degree of protection:	IP66, IP67 to EN 60529
Installation altitude above sea level:	max. 2,000 m
Protection class:	III
Resistance to shock:	30 g / 11 ms
Resistance to vibration:	10 ... 150 Hz, amplitude 0.35 mm
Insulation values to EN 60664-1:	
- Rated insulation voltage U_i :	32 VDC
- Rated impulse withstand voltage U_{imp} :	0.8 kV
- Over-voltage category:	III
- Degree of pollution:	3
Switching frequency:	≤ 1 Hz
Electrical Data	
Operating voltage U_B :	24 VDC -15% / +10% (stabilised PELV power supply)
No-load supply current I_0 :	≤ 0.05 A
Operating current device with magnet switched on:	
- Averaged:	< 0.2 A
- Peak current:	< 0.7 A / 100 ms
Required rated short-circuit current:	100 A
External cable and device fuse rating:	
- Screw terminals or cage clamps:	4 A gG when used in accordance with UL 508,
- Connector plug M12:	≤ 2 A gG
Electrical data - Safety inputs	
Safety inputs:	X1 and X2
Switching thresholds:	- 3 V ... 5 V (Low), 15 V ... 30 V (High)
Current consumption per input:	typically 2 mA / 24 V

Accepted test pulse duration on input signal:	≤ 1.0 ms				
- With test pulse interval of:	≥ 100 ms				
Classification:	ZVEI CB24I				
Sink:	C1	Source:	C1	C2	C3

Electrical data – Safety outputs

Safety outputs:	Y1 and Y2				
Switching elements:	OSSD, p-type, short-circuit proof				
Utilisation category:	DC-13				
- Rated operating voltage U_e :	24 VDC				
- Rated operating current I_e :	each max. 0.25 A				
Leakage current I_l :	≤ 0.5 mA				
Voltage drop U_d :	≤ 4 V				
Cross-wire monitoring by device:	Yes				
Test pulse duration:	< 0.5 ms				
Test pulse interval:	1,000 ms				
Classification:	ZVEI CB24I				
Source:	C2	Sink:	C1	C2	

Electrical data – Diagnostic output

Diagnostic output:	OUT
Switching element:	p-type, short-circuit proof
Utilisation category:	DC-13
- Rated operating voltage U_e :	24 VDC
- Rated operating current I_e :	max. 0.05 A
Voltage drop U_d :	≤ 4 V

Electrical data – Magnet control

Solenoid input:	IN				
Switching thresholds:	- 3 V ... 5 V (Low), 15 V ... 30 V (High)				
Power consumption:	typical 10 mA / 24 V, dynamic 20 mA				
Magnet switch-on time	100%				
Accepted test pulse duration on input signal:	≤ 5.0 ms				
- With test pulse interval of:	≥ 40 ms				
Classification:	ZVEI CB24I				
Sink:	C0	Source:	C1	C2	C3

Serial diagnostic SD

Operating current:	0.15 A
Wiring capacitance:	max. 50 nF



Use isolated power supply only.
For use in NFPA 79 Applications only.
Adapters providing field wiring means are available from
the manufacturer. Refer to manufacturers information.



This device complies with part 15 of the FCC Rules and contains
licence-exempt transmitter(s)/receiver(s) that comply with Innovation,
Science and Economic Development Canada's licence-exempt
RSS(s):
Operation is subject to the following two conditions:
(1) This device may not cause harmful interference, and
(2) this device must accept any interference received, including
interference that may cause undesired operation.
This device complies with the Nerve Stimulation Exposure Limits
(ISED SPR-002) for direct touch operations.
Changes or modifications not expressly approved by
K.A. Schmersal GmbH & Co. KG could void the user's authority to
operate the equipment.

L'émetteur/récepteur exempt de licence contenu dans le présent
appareil est conforme aux CNR d'Innovation, Sciences et
Développement économique Canada applicables aux appareils radio
exempts de licence.
L'exploitation est autorisée aux deux conditions suivantes:
(1) L'appareil ne doit pas produire de brouillage.
(2) L'appareil doit accepter tout brouillage radioélectrique subi, même
si le brouillage est susceptible d'en compromettre le fonctionnement.
Cet appareil est conforme aux limites d'exposition relatives à la
stimulation des nerfs (ISED CNR-102) pour les opérations tactiles
directes. Changements ou modifications non expressément approuvés
par K.A. Schmersal GmbH & Co. KG pourraient annuler le droit de
l'utilisateur à utiliser l'équipement.

2.6 Safety classification - of the interlocking function

Standards:	EN ISO 13849-1, EN 61508
PL:	up to e
Control category:	4
PFH:	1.9×10^{-9} / h
PFD:	1.6×10^{-4}
SIL:	suitable for SIL 3 applications
Mission time:	20 years

- of the guard locking function

Standards:	EN ISO 13849-1, EN 61508
PL:	up to d
Control category:	2
PFH:	1.0×10^{-8} / h
PFD:	8.9×10^{-4}
SIL:	suitable for SIL 2 applications
Mission time:	20 years



The safety consideration of the guard locking function only applies for standard devices with monitored solenoid interlock AZM201Z-...-1P2PW-... (see Ordering code). A safety assessment of the guard locking function for devices with serial diagnostics "SD2P" is not allowed due to the non-safe locking/unlocking signal from the SD Gateway



The actuation of the interlock must be compared externally with the OSSD release. If a shut-down now occurs due to an unintentional unlocking this is detected by an external diagnostic.



If for a certain application the power to unlock version of a solenoid interlock cannot be used, then for this exception an interlock with power to lock can be used if additional safety measure need to be realised that have an equivalent safety level.



The safety analysis of the guard locking function refers to the component solenoid interlock AZM as part of the complete system. On the customer side further measures such as safe actuation and safe cable installation to prevent faults are to be implemented. In the event of a fault resulting in the unlocking of the guard locking, this is detected by the solenoid interlock and the safety gates Y1/Y2 switch off. When such a fault occurs the protection equipment may open immediately, just once, before the safe condition of the machine is reached. The system reaction of category 2 allows that a fault can occur between tests causing the loss of the safety function which is detected by the test.

3. Mounting

3.1 General mounting instructions



Please observe the relevant requirements of the standards ISO 12100, ISO 14119 and ISO 14120.

For fitting the solenoid interlock, two mounting holes for M6 screws with washers (washers included in delivery) are provided. The solenoid interlock must not be used as an end stop. Any mounting position. The mounting position however must be chosen so that the ingress of dirt and soiling in the used opening is avoided. The unused actuator opening must be sealed by means of the dust-proof flap (included in delivery).

Minimum distance between two solenoid interlocks
as well as other systems with same frequency (125 kHz): 100 mm.

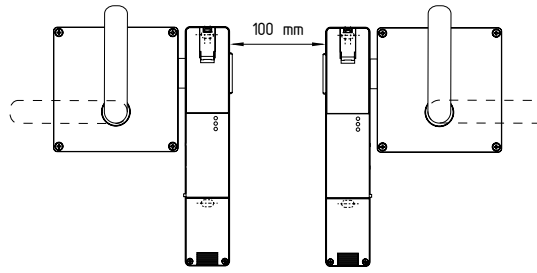

Mounting of the solenoid interlock and the actuator

Refer to the mounting instructions manual for the corresponding actuator.



The actuator must be permanently fitted to the safety guards and protected against displacement by suitable measures (tamperproof screws, gluing, drilling of the screw heads).

Manual release

For the machine set-up, the solenoid interlock can be unlocked in a de-energised condition. After opening of the plastic flap "A" (refer to image "Dimensions"), the triangular key must be turned clockwise to bring the blocking bolt in unlocking condition. The normal locking function is only restored after the triangular key has been returned to its original position.



Caution: do not turn beyond the latching point, maximum tightening torque: 1.3 Nm.

After being put into operation, the manual release must be secured by closing the plastic flap "A" and affixing the seal, which is included in delivery.

Component ready for operation

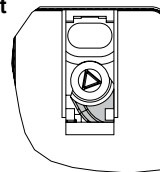

Component not ready for operation

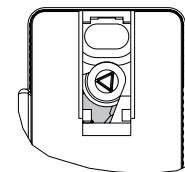

3.2 Dimensions

All measurements in mm.

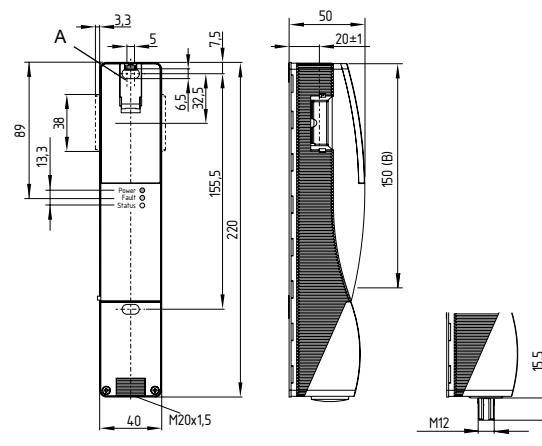

Key

- A: Manual release
- B: Active RFID area



Metal parts and magnetic fields in the lateral RFID area of the solenoid interlock and the actuator can influence the switching distance or lead to malfunctions.

3.3 Retrofit kit for Manual release/Emergency exit

The retrofit kit is used for subsequent functional expansion of the solenoid interlock.

	Designation	Ordering code
Emergency release	RF-AZM200-N	103003543
Emergency exit	RF-AZM200-T	103004966

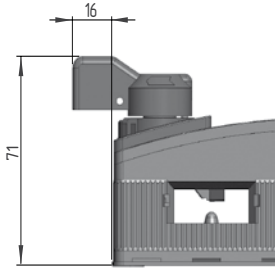

4. Electrical connection

4.1 General information for electrical connection



The electrical connection may only be carried out by authorised personnel in a de-energised condition.

The power supply for the solenoid interlock must provide protection against permanent overvoltage. To that effect, stabilised PELV supply units must be used. The required electrical cable and device fuse protection must be integrated in the installation.

The safety outputs can be directly integrated in the safety circuit of the control system. For applications up to PL e / control category 4 in accordance with EN ISO 13849-1, the safety outputs of the safety switch must have an assessment with the same category (refer to wiring examples). Inductive loads (e.g. contactors, relays, etc.) are to be provided with suitable interference suppression circuitry.



The fitted 24V, X1, X2 bridge is included in the delivery of ...-1P2PW and ...-SD2P.

Requirements for the connected safety-monitoring module:

- Dual-channel safety input, suitable for 2 p-type semi-conductor outputs



Configuration of the safety controller

If the safety switchgear is connected to electronic safety-monitoring modules, we recommend that you set a discrepancy time of 100 ms. The safety inputs of the safety-monitoring module must be able to blank a test impulse of approx. 1 ms. The safety-monitoring module does not need to have a cross-wire short monitoring function, if necessary, the cross-wire short monitoring function must be disabled.



Information for the selection of suitable safety-monitoring modules can be found in the Schmersal catalogues or in the online catalogue on the Internet: products.schmersal.com.

If the safety component is wired to relays or to non-safety relevant control components, a new risk analysis must be carried out.



Accessories for the series-wiring

For convenient wiring and series-wiring of SD components, the SD junction boxes PFB-SD-4M12-SD (variant for the field) and PDM-SD-4CC-SD (variant for control cabinet on carrier rail) are available along with additional comprehensive accessories. Detailed information is available on the Internet, products.schmersal.com.



On wiring SD devices, please pay attention to the voltage drop on the cables and the current carrying capacity of the individual components.

4.2 Cable

The cable entry is realised by a metric M20 gland. This gland must be measured by the user so that it is suitable for the cable used. A cable gland with strain relief and suitable IP protection class must be used.

Settle length x of the conductor:

- on screw terminals (SK): 8.0 mm
- on cage clamps (CC) of type s, r or f: 7.5 mm

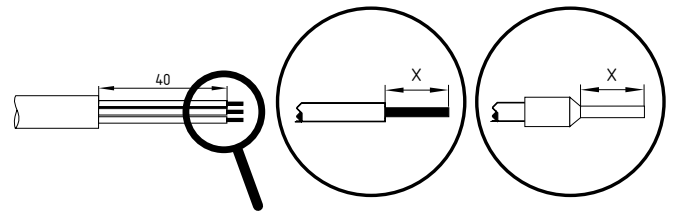

5. Operating principle and actuator coding

5.1 Magnet control

In the power to unlock version of the AZM201, the solenoid interlock is unlocked when the IN signal (= 24V) is set. In the power to lock version of the AZM201, the solenoid interlock is locked when the IN signal (= 24 V) is set.

5.2 Mode of operation of the safety outputs

In the standard AZM201 variant, the unlocking of the solenoid interlock causes the safety outputs to be disabled. The unlocked safety guard can be relocked as long as the actuator is inserted in the AZM201 solenoid interlock; in that case, the safety outputs are re-enabled. **It is not necessary to open the safety guard.**

In the B-variant AZM201B, the opening of the safety guard causes the safety outputs to be disabled.

5.3 Actuator teaching / actuator detection

Solenoid interlocks with standard coding are ready to use upon delivery.

Individually coded solenoid interlocks and actuators will require the following "teach-in" procedure:

1. Switch the solenoid interlock's voltage supply off and back on.
2. Introduce the actuator in the detection range. The teach-in procedure is signalled at the solenoid interlock, green LED off, red LED on, yellow LED flashes (1 Hz).
3. After 10 seconds, brief yellow cyclic flashes (5 Hz) request the switch-off of the operating voltage of the solenoid interlock. (If the voltage is not switched off within 5 minutes, the solenoid interlock cancels the "teach-in" procedure and signals a false actuator by 5 red flashes).
4. After the operating voltage is switched back on, the actuator must be detected once more in order to activate the taught actuator code. In this way, the activated code is definitively saved!

For ordering suffix -I1, the executed allocation of safety interlock and actuator is irreversible.

For ordering suffix -I2, the "teach-in" procedure for a new actuator can be repeated an unlimited number of times. When a new actuator is taught, the code, which was applicable until that moment, becomes invalid. Subsequent to that, an enabling inhibit will be active for ten minutes, thus providing for an increased protection against tampering. The green LED will flash until the expiration of the time of the enabling inhibit and the detection of the new actuator. In case of power failure during the lapse of time, the 10-minutes tampering protection time will restart.

6. Diagnostic functions

6.1 Diagnostic-LEDs

The solenoid interlock signals the operational state as well as errors through three coloured LED's installed on the front side of the device.

green (Power)	Supply voltage on
yellow (Status)	Operating condition
red (Fault)	Error (see table: Error messages / flash codes red diagnostic LED)

6.2 Solenoid interlock with conventional diagnostic output

The short-circuit proof diagnostic output can be used for central visualisation or control functions, e.g. in a PLC.

The diagnostic output is not a safety-related output.

Error

Errors, which no longer guarantee the function of the solenoid interlock (internal errors) cause the safety outputs to be disabled immediately. Any error that does not immediately affect the safe functionality of the solenoid interlock (e.g. excess ambient temperature, safety output to external potential, short circuit) will lead to a delayed shut-down (refer to table 2).

After fault rectification, the sensor can be reset by opening and relocking the relevant guard door. The safety outputs enable and allow a restart. An interlocking chain must be permanently "locked" to enable the reactivation.



Automatic, electronic locking takes place if more than one fault is detected at the safety outputs or a cross circuit is detected between Y1 and Y2. This means that normal fault acknowledgement is no longer possible. To reset this type of interlocking, the solenoid interlock must be isolated from the power supply after elimination of the error causes.

Error warning

A fault has occurred, which causes the safety outputs to be disabled after 30 minutes. The safety outputs initially remain enabled. This signal combination, diagnostic output disabled and safety channels still enabled, can be used to stop the production process in a controlled manner. An error warning is deleted when the cause of error is eliminated.

Behaviour of the diagnostic output (Version ...-1P2PW)
(Example: power to unlock version)

Input signal magnet control

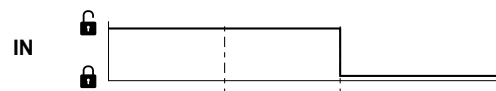

Normal sequence, door was locked

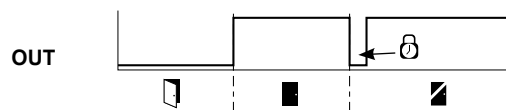

Door could not be locked or fault

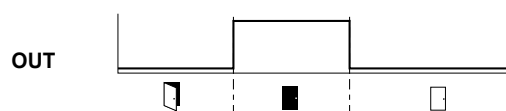

Key

Lock	Unlock
Safety guard open	Safety guard closed
Safety guard not locked or fault	Safety guard locked

Locking time: 150 ... 250 ms, typically 200 ms

Evaluation of the diagnostic output (Version ...-1P2PW)

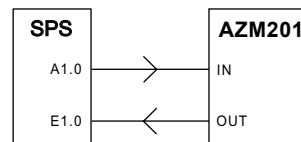

Power to unlock: IN = 0 = locking

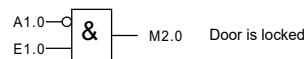

Power to lock: IN = 1 = locking

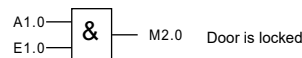
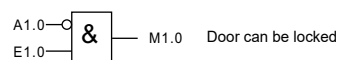

Table 1: Diagnostic information for the safety switchgear

The safety switch signals the switching condition as well as malfunctions via three coloured LEDs installed on the device.

System condition	Solenoid control IN		LED			Safety outputs Y1, Y2		Diagnostic output OUT -1P2PW
	Power to unlock	Power to lock	green	red	yellow	AZM201Z	AZM201B	
Guard open	24 V (0 V)	0 V (24 V)	On	Off	Off	0 V	0 V	0 V
Door closed, actuator not inserted	24 V	0 V	On	Off	Off	0 V	0 V	0 V
Door closed, actuator inserted, not locked	24 V	0 V	On	Off	Flashes	0 V	24 V	24 V
Door closed, actuator inserted, interlocking blocked	0 V	24 V	On	Off	Flashes	0 V	24 V	0 V
Guard closed, actuator inserted and locked	0 V	24 V	On	Off	On	24 V	24 V	24 V
Error warning¹⁾ solenoid interlock locked	0 V	24 V	On	Flashes ²⁾	On	24 V ¹⁾	24 V ¹⁾	0 V
Error	0 V (24 V)	24 V (0 V)	On	Flashes ²⁾ / Off ³⁾	Off	0 V	0 V	0 V
Additionally for variant I1/I2:								
Teach-in procedure actuator started			Off	On	Flashes	0 V	0 V	0 V
Only I2: teach-in procedure actuator (release block)			Flashes	Off	Off	0 V	0 V	0 V

¹⁾ after 30 min: disabling due to fault

²⁾ refer to flash code

³⁾ after autonomous switch-off after 30 minutes for error temperature too high

Table 2: Error messages / flash codes red diagnostic LED

Flash codes (red)	Designation	Autonomous switch-off after	Error cause
1 flash pulse	Error (warning) at output Y1	30 min	Fault in output test or voltage at output Y1, although the output is disabled.
2 flash pulses	Error (warning) at output Y2	30 min	Fault in output test or voltage at output Y2, although the output is disabled.
3 flash pulses	Error (warning) cross-wire short	30 min	Cross-wire short between the output cables or fault at both outputs
4 flash pulses	Error (warning) temperature too high	30 min	The temperature measurement reveals an internal temperature that is too high
5 flash pulses	Actuator fault	0 min	Incorrect or defective actuator
6 flash pulses	Error actuator combination	0 min	An invalid combination of actuators was detected (blocking bolt detection or tamper attempt).
Continuous red	Internal fault / overvoltage or undervoltage fault	0 min	Device defective / supply voltage not within specifications

6.3 Solenoid interlock with serial diagnostic function SD

Solenoid interlocks with serial diagnostic cable have a serial input and output cable instead of the conventional diagnostic output. If solenoid interlocks are wired in series, the diagnostic data is transmitted through the series-wiring of the inputs and outputs.

Max. 31 solenoid interlocks can be wired in series. For the evaluation of the serial diagnostics line either the PROFIBUS-Gateway SD-I-DP-V0-2 or the Universal-Gateway SD-I-U-... are used. This serial diagnostic interface is integrated as a slave in an existing field bus system. In this way, the diagnostic signals can be evaluated by means of a PLC. The necessary software for the integration of the SD-Gateway is available for download at products.schmersal.com.

The response data and the diagnostic data are automatically and permanently written in an input byte of the PLC for each solenoid interlock in the series-wired chain. The request data for each solenoid interlock is transmitted to the component through an output byte of the PLC. In case of a communication error between the SD-gateway and the solenoid interlock, the switching condition of the solenoid interlock is maintained.

Error

A fault has occurred, which causes the safety outputs to be disabled. The fault is reset, when the cause is eliminated and bit 7 of the request byte changes from 1 to 0 or the safety guard is opened. Faults at the safety outputs are only deleted upon the next release, as the fault rectification cannot be detected sooner.



Automatic, electronic locking takes place if more than one fault is detected at the safety outputs or a cross circuit is detected between Y1 and Y2. This means that normal fault acknowledgement is no longer possible. To reset this type of interlocking, the solenoid interlock must be isolated from the power supply after elimination of the error causes.

Error warning

A fault has occurred, which causes the safety outputs to be disabled after 30 minutes. The safety outputs initially remain enabled. This enables the shutdown of the process in a controlled manner. An error warning is deleted when the cause of error is eliminated.

Diagnostic error (warning)

If an error (warning) is signalled in the response byte, detailed fault information can be read out.

Table 3: I/O data and diagnostic data

The described condition is reached, when Bit = 1

Bit n°	Request byte	Response byte	Diagnostic error warning	Diagnostic error
Bit 0:	Magnet in, irrespective of power to lock or power to unlock principle	Safety output activated	Error output Y1	Error output Y1
Bit 1:	---	Actuator detected	Error output Y2	Error output Y2
Bit 2:	---	Actuator detected and locked	Cross-wire short	Cross-wire short
Bit 3:	---	---	Temperature too high	Temperature too high
Bit 4:	---	Input condition X1 and X2	---	Incorrect or defective actuator
Bit 5:	---	Guard door detected	Internal device error	Internal device error
Bit 6:	---	Error warning ¹⁾	Communication error between the field bus Gateway and the safety switchgear	---
Bit 7:	Error reset	Error (enabling path switched off)	Operating voltage too low	---

¹⁾ after 30 min -> fault

7. Set-up and maintenance

7.1 Functional testing

The safety function of the safety components must be tested. The following conditions must be previously checked and met:

1. Fitting of the solenoid interlock and the actuator
2. Check the integrity of the cable entry and connections
3. Check the switch enclosure for damage

7.2 Maintenance

We recommend a regular visual inspection and functional test, including the following steps:

1. Check for tight installation of the actuator and the switch
2. Check maximum axial offset of actuator unit and safety switch.
3. Remove particles of dust and soiling
4. Check cable entry and connections



Adequate measures must be taken to ensure protection against tampering either to prevent tampering of the safety guard, for instance by means of replacement actuators.

Damaged or defective components must be replaced.

8. Disassembly and disposal

8.1 Disassembly

The safety switchgear must be disassembled in a de-energised condition only.

8.2 Disposal

The safety switchgear must be disposed of in an appropriate manner in accordance with the national prescriptions and legislations.

9. Appendix

9.1 Wiring examples

The application examples shown are suggestions. They however do not release the user from carefully checking whether the switchgear and its set-up are suitable for the individual application.

Wiring example 1: Series-wiring of the AZM201 with conventional diagnostic output

In the series-wiring, the 24V-X1-X2 bridge must be removed from all components up to the last component.

The voltage is supplied at both safety inputs of the terminal safety component of the chain (considered from the safety-monitoring module). The safety outputs of the first safety component are wired to the safety-monitoring module.

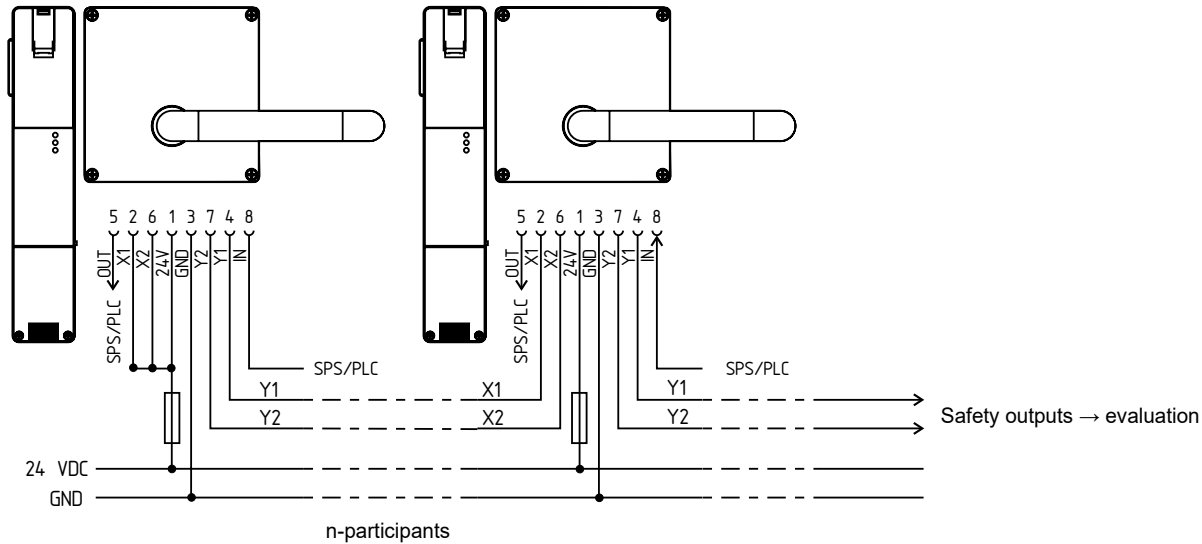

Wiring example 2: Series-wiring of the AZM201 with serial diagnostic function

The safety outputs of the first safety component are wired to the safety-monitoring module. The serial Diagnostic Gateway is connected to the serial diagnostic input of the first safety component.

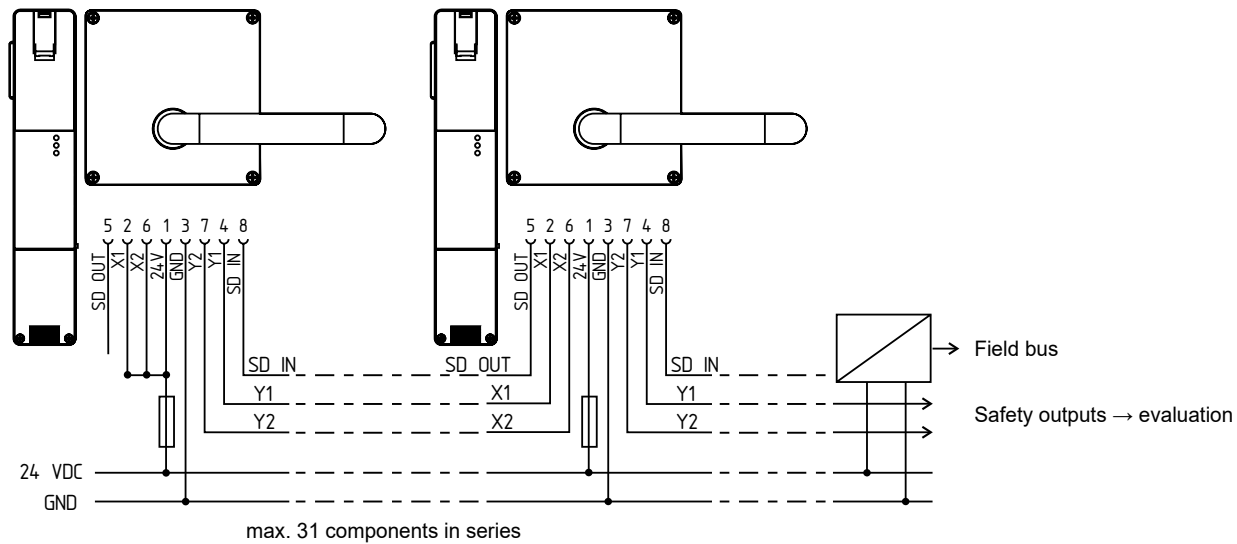

9.2 Wiring configuration and accessories

Function safety switchgear		Pin configuration of the connector	Configuration of the removable terminal blocks	Colour code of the Schmersal connector to DIN 47100	Possible colour code of other commercially available connectors according to EN 60947-5-2	
with conventional diagnostic output	with serial diagnostic function					
24 V	U _e		1	1	WH	BN
X1	Safety input 1		2	2	BN	WH
GND	GND		3	5	GN	BU
Y1	Safety output 1		4	7	YE	BK
OUT	Diagnostic output	SD output	5	9	GY	GY
X2	Safety input 2		6	3	PK	PK
Y2	Safety output 2		7	8	BU	VT
IN	Solenoid control	SD input	8	4	RD	OR
	without function		–	6		

View of the terminal block for ordering suffix -SK or -CC

24V	24V	X1	X2	IN
AZM201...-1P2PW-				
GND		Y1	Y2	OUT

24V	24V	X1	X2	IN
AZM201...-SD2P-				
GND		Y1	Y2	OUT

View of the version with removable terminal blocks

1	2	3	4
AZM201...-1P2PW-			
5	6	7	8

Connector plug ST2 M12, 8-pole



Accessories: Pre-wired cables

Connecting cables with coupling (female) IP67, M12, 8-polig – 8 x 0.25 mm²

Cable length	Ordering code
2.5 m	103011415
5.0 m	103007358
10.0 m	103007359

Further versions in other lengths and with angled cable exit are available upon request.

10. EU Declaration of conformity

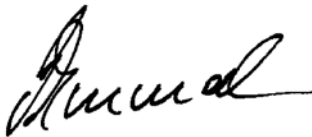
EU Declaration of conformity		
Original	K.A. Schmersal GmbH & Co. KG Möddinghofe 30 42279 Wuppertal Germany Internet: www.schmersal.com	
We hereby certify that the hereafter described components both in their basic design and construction conform to the applicable European Directives.		
Name of the component:	AZM201	
Type:	See ordering code	
Description of the component:	Interlocking device with electromagnetic interlock for safety functions	
Relevant Directives:	Machinery Directive	2006/42/EC
	RED-Directive	2014/53/EU
	RoHS-Directive	2011/65/EU
Applied standards:	EN 60947-5-3:2013 ISO 14119:2013 EN 300 330 V2.1.1:2017 EN ISO 13849-1:2015 EN 61508 parts 1-7:2010	
Notified body for the prototype test:	TÜV Rheinland Industrie Service GmbH Am Grauen Stein, 51105 Köln ID n°: 0035	
EC-prototype test certificate:	01/205/5608.00/17	
Person authorised for the compilation of the technical documentation:	Oliver Wacker Möddinghofe 30 42279 Wuppertal	
Place and date of issue:	Wuppertal, February 18, 2021	
		
	Authorised signature Philip Schmersal Managing Director	

AZM201-H-EN



The currently valid declaration of conformity can be downloaded from the internet at products.schmersal.com.

