

Absolute encoders - SSI / BiSS

Shaft with clamping or synchro flange
Single turn 9...14 bit,
Multi turn 0...32 bit

FNC AS 458B Series



Features

- Encoder single - or multiturn / SSI - BiSS
- Magnetic Sensing
- Magnetic Single turn Resolution: 9...14 bit
- Multi turn 0...32 bit
- Clamping flange or synchro flange
- Permanent check of code continuity
- Extreme resistance to shock and vibration
- Encoder with electronic reset

Technical data - electrical ratings

Voltage supply	8VDC to 30VDC
Protection:	Output short circuit protection. Reverse polarity protection (except 5V version)
Consumption w/o load	≤80 mA (24 VDC)
Interface	SSI or BiSS
Resolution (steps/turn)	up to 14 bit
Absolute accuracy (magnetic)	±0.35°
Optoelectronic life time	100.000 (min)
Code	Gray or binary
Inputs	SSI differential clock Direction Electronic zero setting
Output frequency	up to 2MHz (SSI) up to 10MHz (BiSS)
Output circuit	SSI data linedriver RS485
Interference immunity	DIN EN 61000-6-2
Emitted interference	DIN EN 61000-6-4
Approval	CE

Technical data - mechanical design

Dimensions (flange)	ø58 mm
Shaft loading	≤20 N axial ≤40 N radial
Protection DIN EN 60529	IP 67
Operating speed	≤10000 rpm
Starting torque	≤0.001 Nm (IP 67)
Materials	Housing, Flange : Aluminium Shaft : Stainless steel
Shaft diameter:	6, 8, 10 mm (other diameters on request)
Bearings lifetime:	2x10 ⁹ rev. at 100% of full rated shaft load (minimum)
Operating temperature	-40...+90°C -40 °F ... +180 °F
Weight approx.	350 g

Pulse Diagram

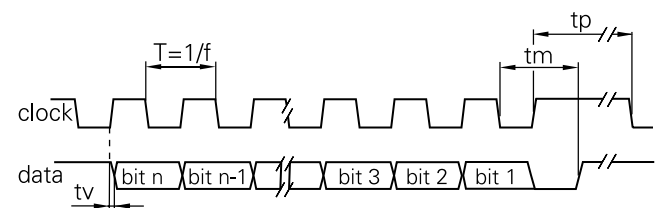

Clock frequency, f	50...2000 kHz for SSI up to 10MHz for BiSS
Code	Binary or gray
Status and parity bit	On request
Monoflop time tm	>15µs
Clock time out	Programmable at factory

Absolute encoders - SSI / BiSS

Mechanical Dimensions
Cable/Connector Wiring, Part Number

FNC AS 458B Series



Mechanical Dimensions

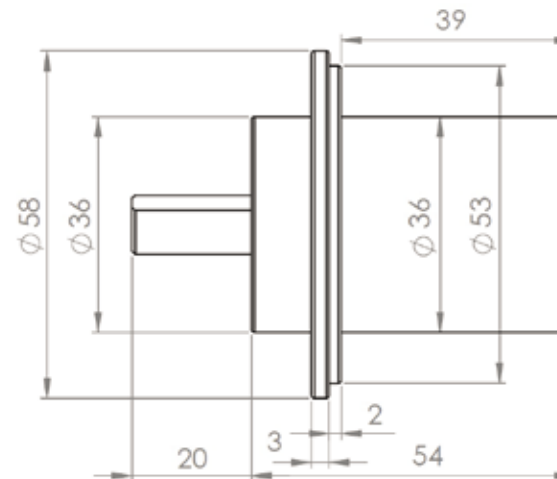
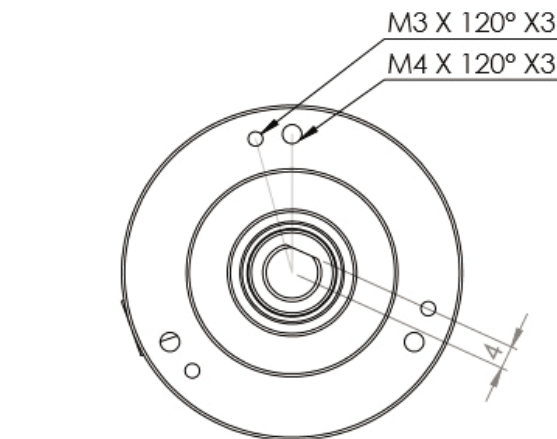

Terminal significance

+Vs	Encoder supply voltage.
0 V	Encoder ground connection relating to +Vs.
Data+	Positive data output.
Data-	Negative data output.
Clock+	Positive SSI clock input.
Clock-	Negative SSI clock input.
Direction	UP/DOWN counting direction input. This input is standart on High. UP/DOWN means ascending output data with clock-wise shaft rotation when looking at flange.
Preset	Parameter for setting the encoder to a requested position value assigned to a defined shaft position of the system. The offset of encoder zero point and mechanical zero point is stored in the encoder.
Note	If needed, Include termination resistor R=120 Ohm between Data+ and Data- on control side.

Encoder Part Number

FNC A S 58 B 10 S12 M12 30V B - R4

- Absolute**
- S**: SSI **B**: BiSS
- Housing: 58** : 58mm
- Flange Type:**
S : Servo flange **B** : Clamping flange
- Shaft diameter : 6, 8, 10**
Other dimensions on request
- S** : Single Turn
12...14 bit options

Electrical Connections:
Cable R4 : radial 4m R1C4 : connector after 1m Cable
Connector: CRM1212 CRM2312L CRM2312R
B: Binary **G**: Gray
Supply Voltage:
30V : 8-30V input
Single turn : 00
Multi turn options : 0, 4, 8, 12, 16, 24, 32